

MAX352 only present on "center" XSRF module (three per trilat module). For other modules, place jumpers between pins 6 and 7 then 10 and 11.

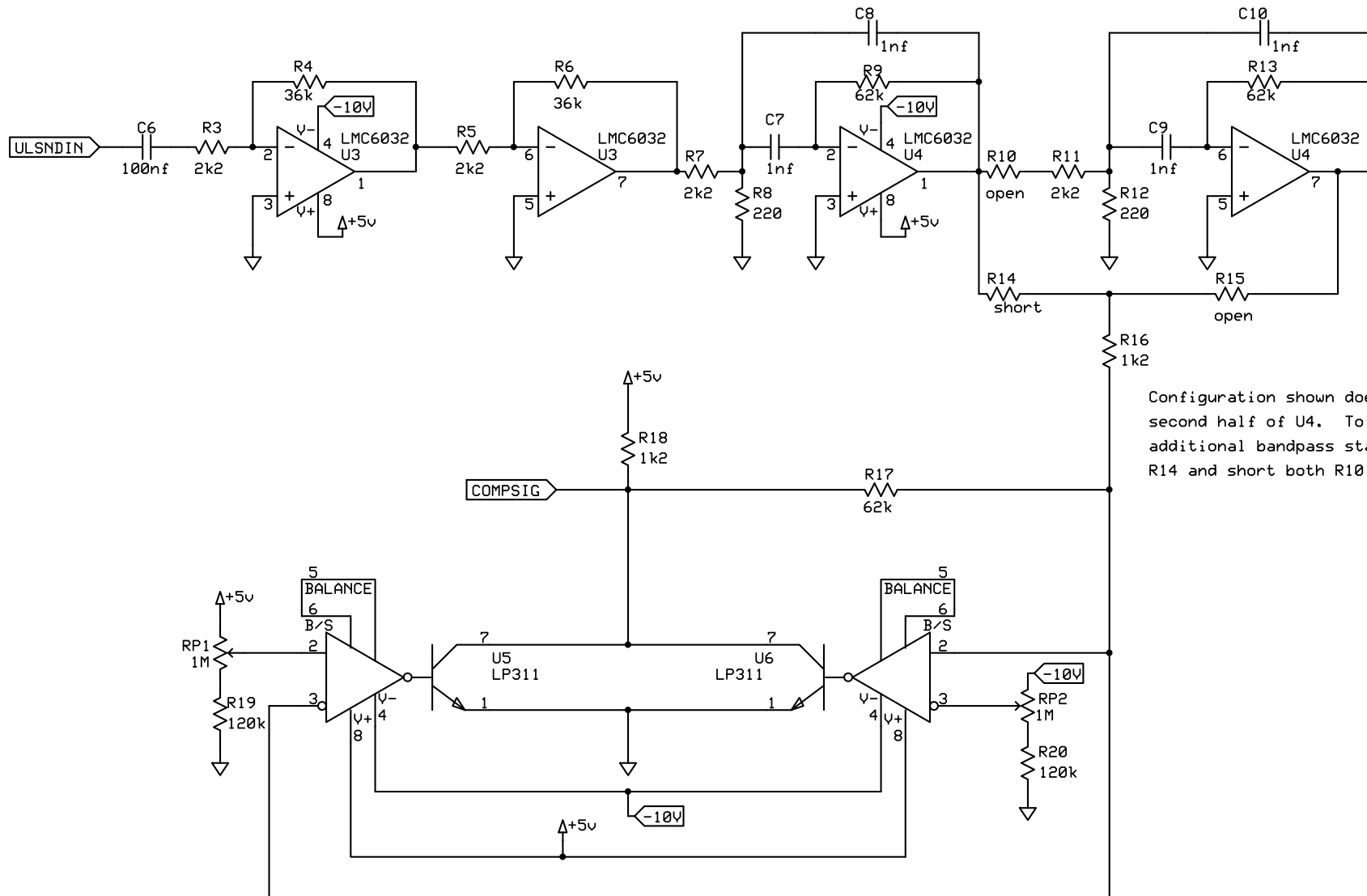

Configuration shown does not use the second half of U4. To insert this additional bandpass stage, open circuit R14 and short both R10 and R15.